

North Park – Maintenance Assessment District Community Advisory Committee Minutes [DRAFT] August 13, 2012

Lucky Morrison, Chair, called the regular meeting of the North Park (NP) Maintenance Assessment District (MAD) Community Advisory Committee to order at 6:05 p.m. at the North Park Adult Activity Center, 2719 Howard Avenue, in San Diego, CA. Lucky noted that Kevin Clark will be the new representative for North Park Main Street. Mike Rasmusson introduced himself as the new City Grounds Maintenance Manager, taking the place of Beethoven Burks.

1. Roll Call

Present:

Lucky Morrison, North Park Planning Committee (NPPC)
Beth Swersie, North Park Community Association (NPCA)
Rob Steppke, North Park Redevelopment Project Area Committee (PAC)
Steve Hon, North Park Historical Society (NPHS)
Kevin Clark, North Park Main Street (NPMS)
Molly Kirkland, San Diego County Apartment Association (SDCAA)
Kitty Callen, Altadena Neighborhood Association (ANA) (arrived approx. at 6:29 pm)

Absent:

Grant Merkel, Burlingame Neighborhood Association (BNA)
Carl Moczydlowsky, Resident Homeowner
Gary Weber, El Cajon Blvd Business Improvement Association (ECBBIA)

City Staff:

Andy Field, Parks and Recreation
Mike Rasmusson, Grounds Maintenance Manager

Guests:

Angela Landsberg (NPMS)

2. Approval of minutes – June 11th meeting (there was no July meeting)

June minutes approved as submitted (Molly/Rob, 5-0-1)

3. Chair's Report

Lucky will be having back surgery in October; Rob will act as Chair in Lucky's absence.

4. Non-agenda Public Comment – none

5. Councilmember's report – Anthony Bernal – not here, no report.

6. Resident Homeowner Seat

Carl has resigned. The committee will take nominations at the September 10th meeting, and will vote at the October 8th meeting. Announcements will be made at community meetings and NPCA and NPMS will post announcements in their newsletters. Beth will serve as contact for inquiries.

7. Committee members introduced themselves to one another and to staff.

8. Staff introduced themselves to committee members.

9. Report on Operational and maintenance issues, Streetscape issues and maintenance update

Andy and Mike reported on operational and maintenance issues. Copies of the Staff Reports for July and August were distributed earlier by email and are attached to these minutes. In addition to the information on that report, there were the following discussions:

- **Boundary Street Gateway:** The “possibly illegal concrete work” near the SDG&E substation on Boundary near El Cajon Blvd appears to be a skatepark being built by kids. City staff will look into it and, if not permitted, will initiate appropriate action.
- **Boundary Street Gateway:** There is an AT&T wireless facility proposal being discussed for Meade/Boundary area, which involves possible trees. Andy said that they have requested the applicant provide a water meter and irrigation to serve the area.
- **Switzer Canyon/30th Street Bridge Enhancement Project:** pedestrian bridge, trees, median estimated at approximately \$300,000 by designer, but Staff thinks it would be much higher. Staff is authorizing funds for a design estimate.
- **Solar Street Lights:** It costs between \$10K and \$18K to install a single new solar light. The costs of parts, repair and maintenance are very high, and there have been wiring problems. The MAD will discuss options.
- **Landscape Contract:** Aztec will provide interim services while the permanent contract is being decided/awarded.

10. City Attorney Memo on Assessment Districts –Information/Discussion

- The conclusion of the memo is that Assessment Districts are meant to provide “special” benefits to those who are assessed, therefore it is necessary to differentiate “special” benefits from “general” benefits, and that it is hard to determine that anything is truly a “special” benefit. The current MAD does not have to address this, but it will need to be considered if reballoting is to be done in the future.
- A discussion will be held at a future meeting to review line items and to evaluate whether they are within our scope, and whether they provide special or general benefits.

11. New business for future agendas

- Nominations for Resident Homeowner seat - September.
- Solar Lights.
- Review of line items.

12. Adjournment at 6:59 pm

Next meeting: September 10, 2012



**THE CITY OF SAN DIEGO
PARK AND RECREATION DEPARTMENT
OPEN SPACE DIVISION
NORTH PARK MAINTENANCE ASSESSMENT DISTRICT
JULY 2012 STAFF REPORT**

El Cajon Boulevard Median

- Aztec is working to repair irrigation and install new plants (to fill in bare spots) in the westernmost median between Park Boulevard and Florida Street. Much of the damage is caused due to trampling.
- No other major issues to report this month.

University Avenue & 30th Street Streetscape

- Staff continues to work with the City's Engineering & Capital Projects Department to identify specific areas of damaged red sidewalk that require repair along University Avenue as part of the future capital project, which may become part of the UAMP (University Avenue Mobility Project).
- No other major issues to report this month.

Street Trees

- The grant to install replacement trees for poorly growing trees in the North Park inventory by Urban Corps is underway. This project should be complete by the timing of this report. Staff has recommended new tree planting for up to approximately 30 locations at various addresses throughout the NP MAD.

Monument Signs

- No major issues to report this month.

Bike Corrals

- Please see attachment for proposed design of bike racks to be incorporated into the bike corral to be located at 30th Street and North Park Way. MAD staff has been informed that this design is acceptable to Traffic Engineering and will not cost any extra to maintain.

Street Lighting Capital Project

- According to project manager Fernando Lasaga, the installation contract with Republic ITS (a general requirements contractor) continues through the City approval process. Construction has not yet begun.

Switzer Canyon/30th Street Bridge Enhancement Project

- The advocate group for the bridge enhancement continues to work on this project, including possible phasing due to limited MAD funding and examining alternate funding sources.
- The advocate group and landscape architect plan to meet with the City Engineer to discuss traffic engineering considerations in July.

Solar Street Lights

- Of the ten solar street lights maintained by the MAD, at least one light (4443 Idaho Street) is currently not working and another light may be dim. YESCO will continue to repair these lights.

Landscape Contract

- A pre-bid conference for the landscape contract bidding process for five MADs including North Park MAD was held on Friday, June 29th for vendors interested in bidding.
- Bid packages will be due to the City's Purchasing & Contracting Department within 10-14 days.
- After tabulation of the bids, MAD staff will begin the process of analyzing all bids and determining the lowest responsible bidder.

Attachment:

1. Bike Corral – proposed bike rack design

Respectfully submitted,

Cory Peterson
District Manager
(619) 685-1356
petersonr@sandiego.gov

Andy Field
Assistant Deputy Director
(619) 685-1307
afield@sandiego.gov



DERO

BIKE BIKE RACK

- *Attractive design*
- *great for sidewalk placement*
- *Makes a bold statement*

The Dero Bike Bike Rack is an eye-catching, functional piece of street art that playfully reminds us that we could be riding our bike today, and rewards those that do with a secure, convenient place to park it.

The Dero Bike Bike Rack forces bikes to lock up parallel with the rack, helping to keep right of ways clear. The rack allows for the wheels and frame of the bike to be secured using a u-style bike lock.



 www.dero.com  1.800.337.6729



 Printed on recycled paper

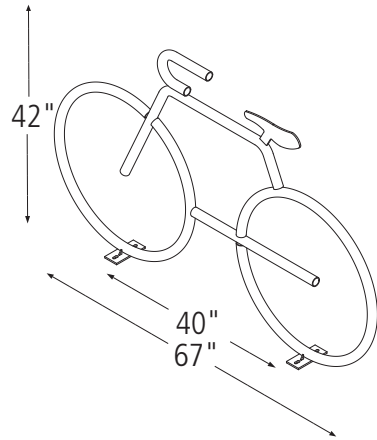

Product Dero Bike Bike Rack
As manufactured by Dero Bike Racks

Capacity 2-4 Bikes

Materials 1.5" OD 11 Gauge Tube. All open ends are capped to prevent moisture from entering. All welds are MIG welds around entire circumference of joined pieces.

Finishes An after fabrication hot dipped galvanized finish is our standard option. 250 TGIC powder coat colors, thermoplastic coating, and stainless steel finishes are also available as alternate options.

Our powder coat finish assures a high level of adhesion and durability by following these steps:

1. Sandblast
2. Epoxy primer electrostatically applied
3. Final thick TGIC polyester powder coat

Stainless Steel: 304 grade stainless steel material finished in either a high polished shine or a satin finish.

Installation Methods Each rack has two 2.5" x 6" mounting brackets double gusset welded to the "wheels". The brackets are 40" apart. Each bracket is anchored to the ground with two anchors. Anchors are included with each rack

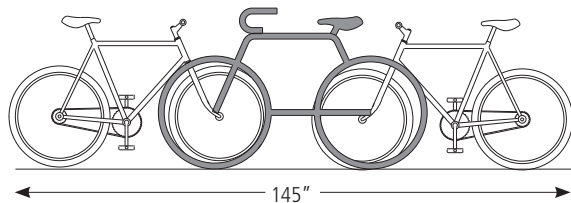

Space Use and Setbacks **Wall Setbacks:** For racks set parallel to a wall: Minimum: 24" Recommended: 36"

For racks set perpendicular to a wall: Minimum: 64" (to allow maximum capacity of 4 bikes)

Distance Between Racks: Minimum: 24" Recommended: 36"

Street Setbacks: Minimum: 36"

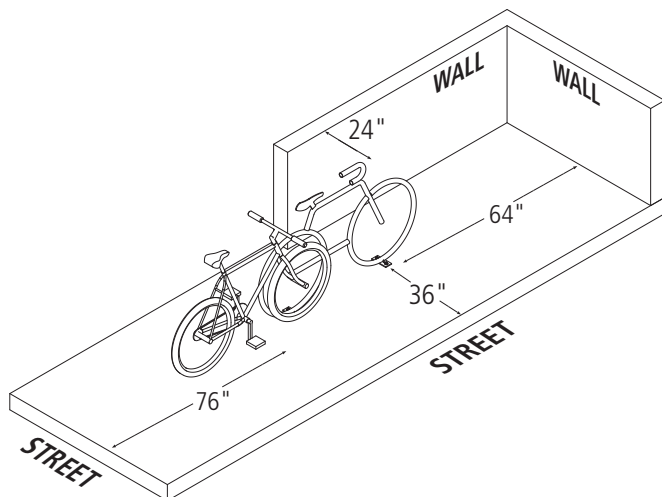



Tools Needed for Installation

- Tape Measure
- Marker or Pencil
- Masonry Drill Bit
- Drill (Hammer drill recommended)
- Hammer
- Wrench
- Level

Recommended Install Base Materials

Solid concrete is the best base material for installation. Ask your Dero Rack representative which anchor is appropriate for your application to ensure the proper anchors are shipped with your rack. Be sure nothing is underneath the base material that could be damaged by drilling.

Installation

3/8" anchors are shipped with the rack. Place the rack in the desired location. Use a marker or pencil to outline the holes of the flange onto the base material. (TIP: If installing more than one Bike Bike Rack, mark holes for each rack individually, as there may be slight differences between each rack). Drill the holes in accordance with the specifications shipped with the anchors. Make sure the holes are at least 6" away from any cracks in the base material. Tap in anchors and follow your specific anchor instructions provided with the rack.

Tamper Resistant Fasteners

More so than standard racks, the Bike Bike Rack may be a target for theft. Therefore we recommend using a fastener that can't be removed by thieves. The concrete spike is a permanent anchor. The top of the wedge anchor can also be pounded sideways after installation so that it cannot be removed. Other tamper resistant fasteners can also be purchased.

When using the special tamper resistant nuts, always set and first tighten the anchors using the standard nuts included with the anchors. Once the rack is installed, replace two nuts from the bracket (opposite sides from each other) with the tamper resistant fastener. DO NOT OVER-TIGHTEN the tamper resistant nut.



If you have any questions about installation or other features of the Bike Bike Rack, please call us toll free at 1-800-298-4915

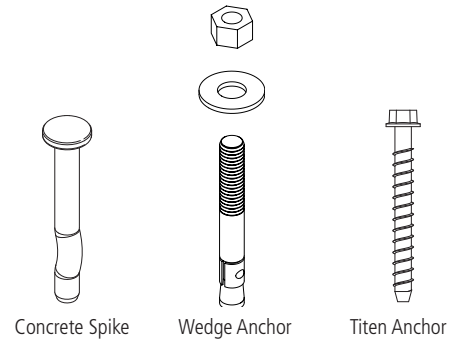

Standard Anchor Types

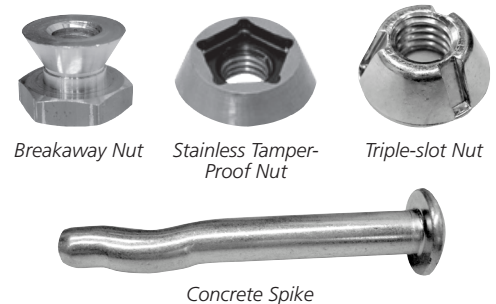
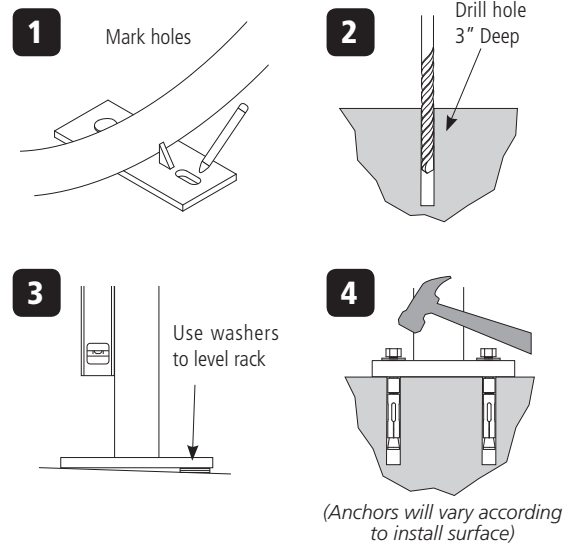



Include Your Organization's Logo!

While the Bike Bike Rack makes a bold statement about bike parking, why not include a bold statement about yourself? Dero Bike Racks can reproduce your logo into the front wheel of the Bike Bike Rack. Logos can be cut from .25" plate steel and welded to the rack for maximum durability.

Of course logos are not the only type of image that can be included with the rack. Why not order a sign that says "Bike Parking", or the name of your city? The possibilities are endless. Contact Dero Bike Racks toll free for pricing of custom imagery: 1-800-298-4915.

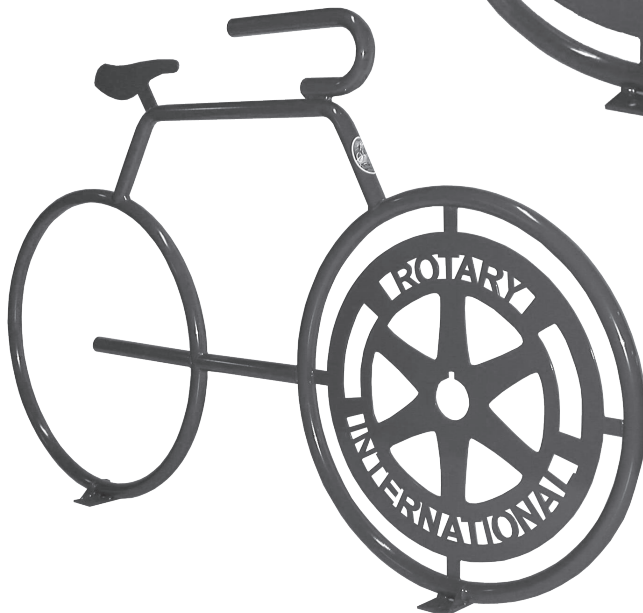
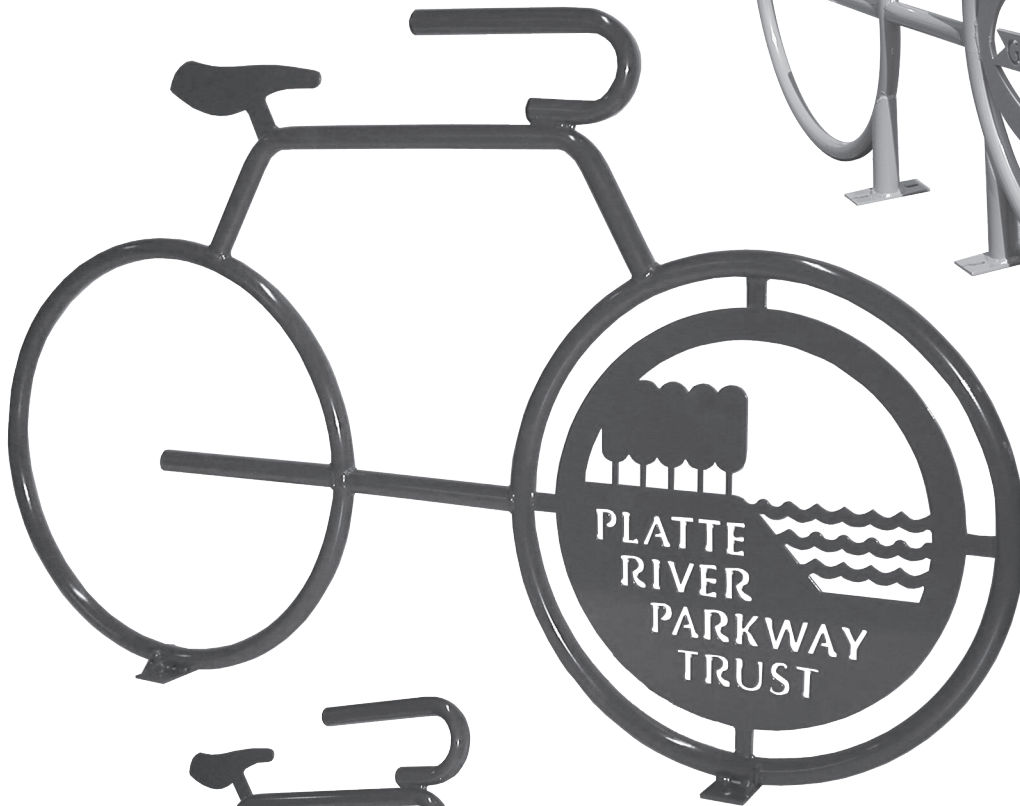



**THE CITY OF SAN DIEGO
PARK AND RECREATION DEPARTMENT
OPEN SPACE DIVISION
NORTH PARK MAINTENANCE ASSESSMENT DISTRICT
AUGUST 2012 STAFF REPORT**

New Grounds Maintenance Manager

- Mike Rasmusson started on August 6 as the new Grounds Maintenance Manager for the North Park MAD, replacing Beethoven Burks. Mike can be reached at 619-685-1352 or MRasmusson@sandiego.gov. Mike will attend the August 13 advisory committee meeting to introduce himself to the committee members.

El Cajon Boulevard Median

- Aztec completed work on the median near The Boulevard sign between Park Boulevard and Georgia Street.
- Staff will refer some eucalyptus tree trimming work along El Cajon Boulevard to the City's Street Division via service request.

University Avenue & 30th Street Streetscape

- On a walkthrough inspection conducted on August 8, staff identified several dead, dying, stunted, or missing trees along University Avenue and 30th Street. One noticeable dying tree is along 30th Street, west side, north of University Avenue. A few missing trees were found near the North Park Theater, both north and south sides of University Avenue. Staff will move toward replacing those trees.
- A few more tiles were noticed missing in the red sidewalk area; staff will work to get the tiles replaced.

Boundary Street Gateway

- Caltrans completed mulching along certain segments of the Interstate 805 freeway slope adjacent to Boundary Street, and some mulch was added to the City's rights of way as well.
- Some possibly illegal concrete work was observed near the SDG&E substation on Boundary Street just south of El Cajon Boulevard. Staff will research this activity to determine if the concrete installed was done with a City-issued permit.

Switzer Canyon/30th Street Bridge Enhancement Project

- The advocate group and Kotaro Nakamura (from Roesling Nakamura Terada Architects) met with the City Engineer on July 20 to discuss the proposed improvement project to the

30th Street Bridge over Switzer Canyon. Mr. Nakamura will provide Andy Field with copies of drawings and simulations, and Andy Field will submit the project through the City's project intake process to the City Engineer to initiate preliminary design and determine the cost of the proposed project.

Solar Street Lights

- YESCO is continuing repair of the solar street lights as they falter. If anyone observes a broken or nonfunctioning solar street light in North Park, please report them to Mike Rasmusson at 619-685-1352 (do not call the Street Division or use their service request system).

Landscape Contract

- The Aztec contract will end this month. An interim contractor will be in place to continue services while the permanent contractor is being awarded.
- MAD staff has analyzed the landscape contract bids received and has recommended an award to the low bidder. This selection needs to be approved by the City's Purchasing & Contracting Department and City Attorney before the contract can be officially awarded.
- The new permanent contractor will assume the responsibility for services currently provided by Urban Corps at a comparable cost.

Respectfully submitted,

Mike Rasmusson
Grounds Maintenance Manager
(619) 685-1352
mrasmusson@saniego.gov

Andy Field
Assistant Deputy Director
(619) 685-1307
afield@saniego.gov